

Spectrum II

Infrared Sound Field System User Guide

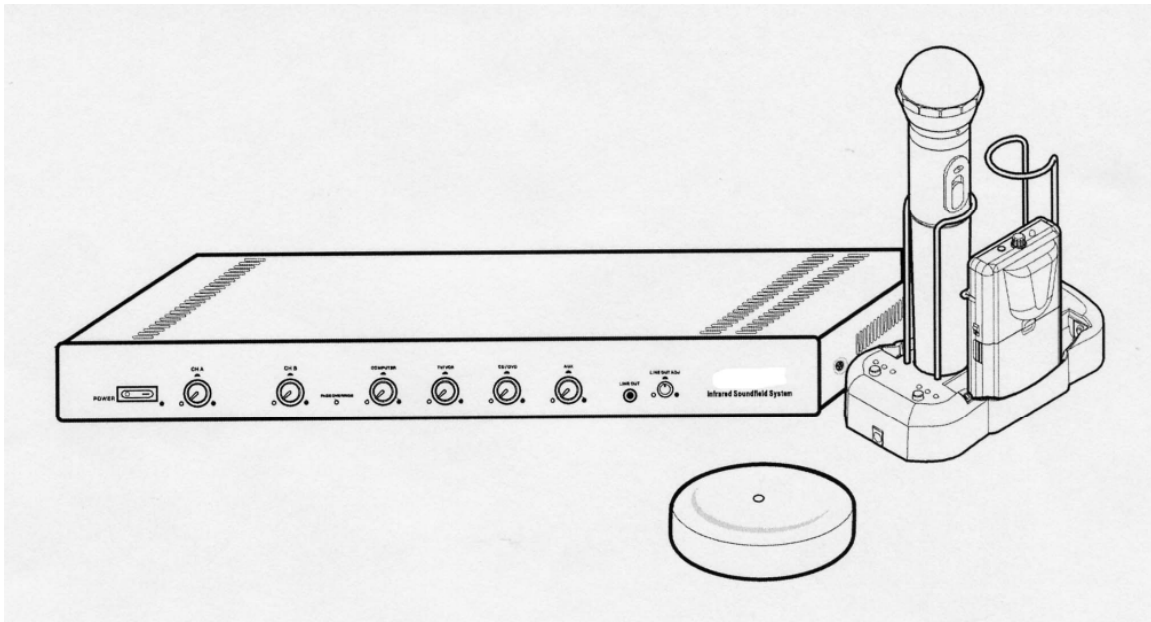

TeachLogic 

FORWARD

Congratulations on the purchase of your new SPECTRUM II sound field system produced by TeachLogic. We are confident that it will perform as specified and fulfill all your expectations. TeachLogic incorporates the most state of the art technology, employs the most advanced manufacturing methodology and uses only premium quality components to assure you many years of reliable performance. Thank you for your confidence in selecting TeachLogic products and we intend to support our products to your complete satisfaction.

We hope you will take some time to review this manual to familiarize yourself with the product features and help you understand its performance. We are confident that the manual will help you gain the maximum use and benefit of the Spectrum II sound field system.

The manual provides some basic explanation on the principle of Infrared transmission and its benefits. First there will be operation instruction followed by installation instruction. The manual will conclude with maintenance procedures and trouble shooting analysis.

If you should encounter any difficulty or need further assistance, contact TeachLogic customer service department.

Telephone Number: 800-588-0018 or email: customerservice@teachlogic.com

Brian Van Waay
President

How the System Works

A Brief Word About Infrared

Infrared is a light ray that is below the visible light spectrum, just like the sound spectrum extends beyond your hearing ability. Infrared transmission is used in the remote control of your TV set. A beam of infrared light is emitted by a Light Emitting Diode (LED) from the remote control and it is detected by a receiving diode in your TV set. When you push a certain command on your control, the internal electronics causes the infrared light to flicker in a programmed sequential pattern (called modulating the light beam). That pattern is detected by the receiving diode and is electronically decoded to send the command to the TV set.

So how does this apply to the infrared communication system which you are about to start using? Well, the body-pack transmitter or handheld microphone has several Light Emitting Diodes (LED) that emit infrared light beams to the sensor located on the ceiling of your room (that dark round dome). Now, when you talk into the microphone, the internal electronics in the handheld or body-pack transmitter causes the light beam to flicker at the same sequence as your breath varies from your voice when you speak into the microphone. That sequential signal is detected by the dome sensor and a coded electronic signal is sent to the receiver in the Spectrum II amplifier. The receiver decodes the electronic signal and converts it into electronic signal. The signal is routed to the amplifier. The amplifier strengthens (amplifies) the electronic signal and makes it strong enough to cause the speaker to move back and forth at the same variation as your breath varied into the microphone. Now the replicate of your voice is produced by the speaker at a strong level so all can hear with ease.

Due to the number and strength of the diodes in the transmitter and sensitivity of the dome sensor, the IR signal will bounce off the walls, ceiling and floor and be received by the sensor without interruption. However, infrared will not penetrate solid surfaces, therefore; transmission will not go out of the room.

“So what’s said in the room, stays in the room”.

Overview of the Operational Features of the Spectrum System

The Spectrum II is the nucleus of the classroom sound field system. The infrared microphone / transmitter (two transmitters can be used simultaneously) transmits the vocal signal to the dome sensor installed in a central location of the ceiling. The signal is then sent via cable to the sensor input of the Spectrum II. Up to four other audio sources, such as; Computer, DVD, Projector, VCR, or iPod can be plugged into the Spectrum II. The volume level of each input and microphone will be controlled by the individual volume control of each input. The audio will then be fed to the speakers in the room.

On the front panel of the Spectrum II, there is a 3.5mm output jack for interface with a personal FM listening system (ALS). The gain control adjusts the signal output level to match the input requirement of the personal system.

There is a line output on the back of the Spectrum II for recording or to feed a signal to another media device.

THE SPECTRUM II SYSTEM

Basic Components Common to All Systems

Spectrum II, Receiver/Amplifier/Mixer (IMA – 700) This is the main unit that has two infrared receivers, three sensor inputs, four stereo auxiliary inputs, one dual line output, page over-ride with page pass through feature, nine band equalizer, front panel output for personal FM assistive listening system, four amplifier outputs and an external in-line power supply. The Spectrum amplifier can be rack-mounted or under-shelf mounted with appropriate mounting kit or free stand on a shelf.

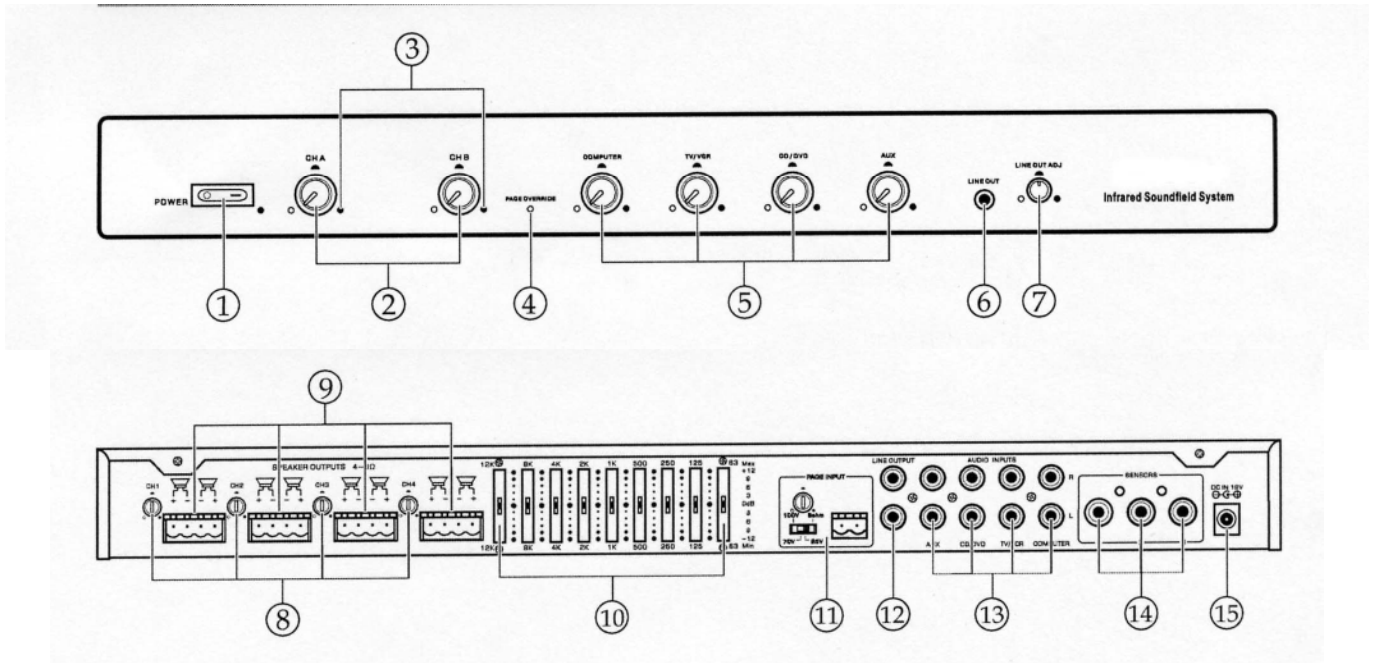

1. Power Switch
2. Infrared wireless volume controls (channel A & B)
3. Infrared wireless transmission LED
4. Page over-ride indicator LED
5. Line input volume controls
6. Signal presence indicator LED
7. Line output (3.5mm)
8. Line output gain control
9. Speaker output volume control
10. Speaker output connection
11. Nine band equalizer
12. Gain control for page override
13. Page signal level selector
14. Page over-ride connection
15. Line output connection
16. Line input connection
17. Sensor input connection
18. Power input connection

Infrared Dome Sensor (ICS – 50) This is the unit that needs to be installed on the ceiling. It comes with a mounting / support bracket and 50 feet of plenum rated cable with RCA connector on each end.

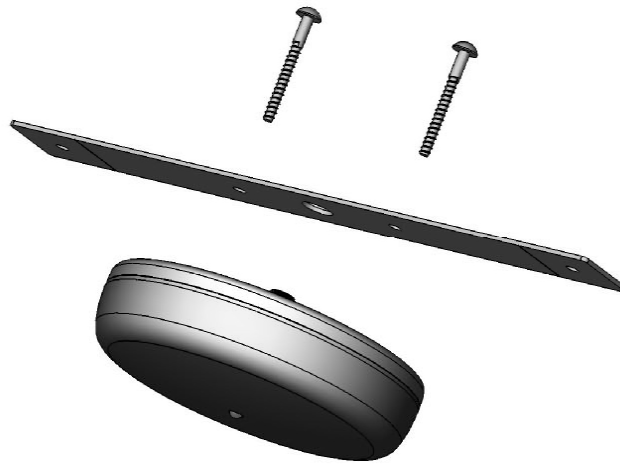

Drop-in Battery Charger (BRC – 30) The charger will be used to recharge the NiMH batteries in the body-pack transmitter and handheld microphone. The charger is powered by an external AC wall adapter. The charger features two grey buttons for recycling the batteries.

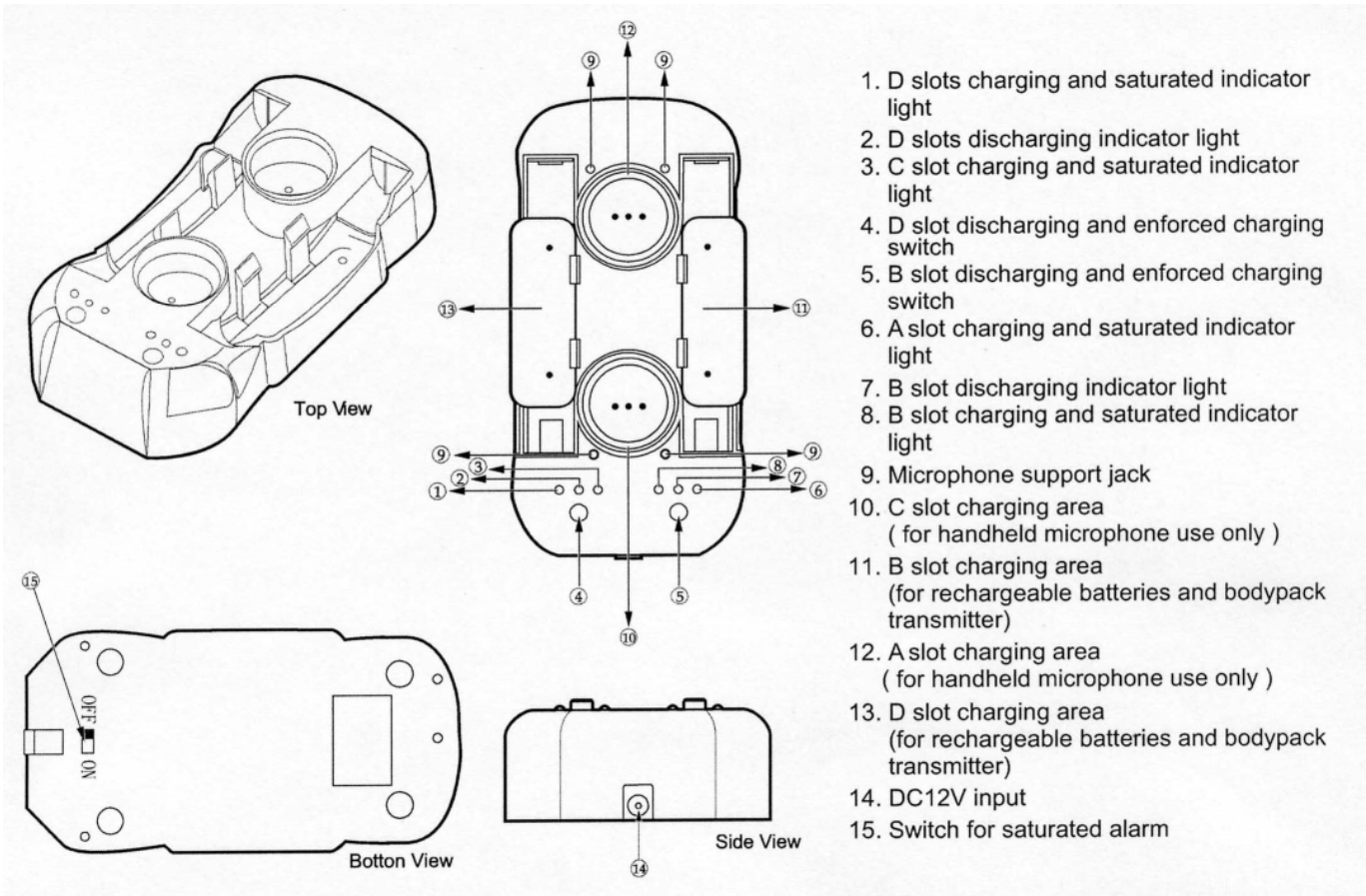

Optional Components per System Specified – *Note the Check List Attached*

Body-Pack transmitter (IRB – 30) The body-pack transmitter has 10 infrared emitting diodes for transmission and has rechargeable NiMH batteries installed. With a microphone plugged into the top and a lanyard provided, it can be worn around the neck as a pendent microphone or be clipped onto a belt with a wired microphone plugged in. The body-pack will fit directly into the drop-in charger and will automatically be connected to the charger upon insertion.

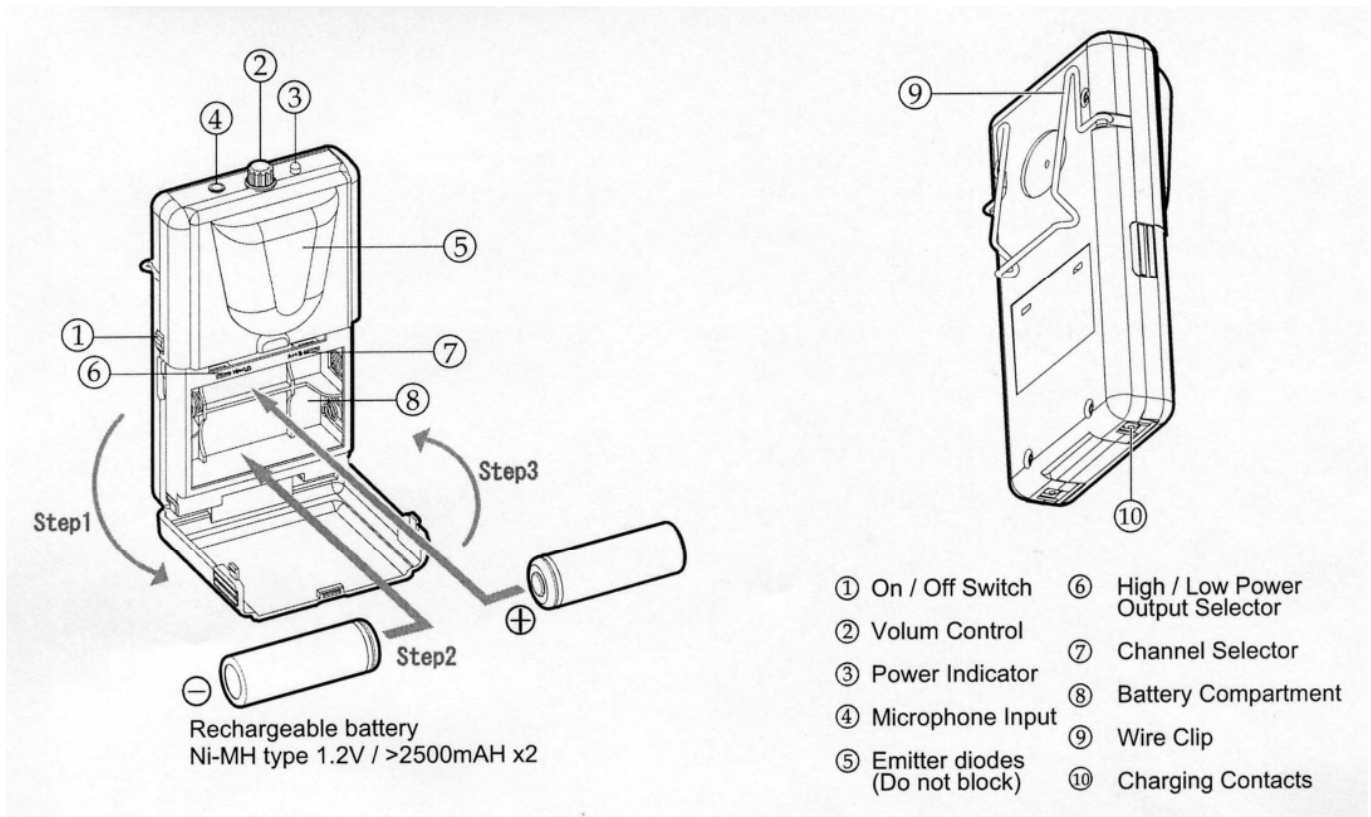

Plug-in Microphone (LM – 300): The plug-in microphone plugs directly into the 3.5mm jack on the top of the transmitter. A lanyard cord is provided to wear the body-pack transmitter around the neck as a pendant microphone. A windscreen is included to reduce breath pops when used in close proximity to the mouth.

UltraLite Mic (ULM – 835): The ultra lite mic is supported by a wire around the ear with a miniature boom mic extending toward the mouth. The mic is plugged into body-pack via the 3.5mm mini plug.

Collar Mic (CM – 835): The collar mic is a flexible rod with a microphone installed in one end. The cord extends from the center of the rod and connects to the body-pack via a 3.5mm mini plug. The rod can be formed to fit around the neck and the mic bent up toward the mouth.

Lapel Microphone (LM – 835): The lapel microphone is a small capsule like microphone with a spring clip for securing on to a clothing edge. The lapel mic is

well suited for use as mic away from the face. The mic is plugged into the top of the body-pack via 3.5mm plug.

Handheld Microphone Transmitter (IRH - 30) The handheld microphone/transmitter has 10 infrared emitting diodes for transmission and has rechargeable NiMH batteries installed. The handheld will fit directly into the drop-in charger and will automatically be connected to the charger upon insertion. The charger will automatically recharge the batteries.

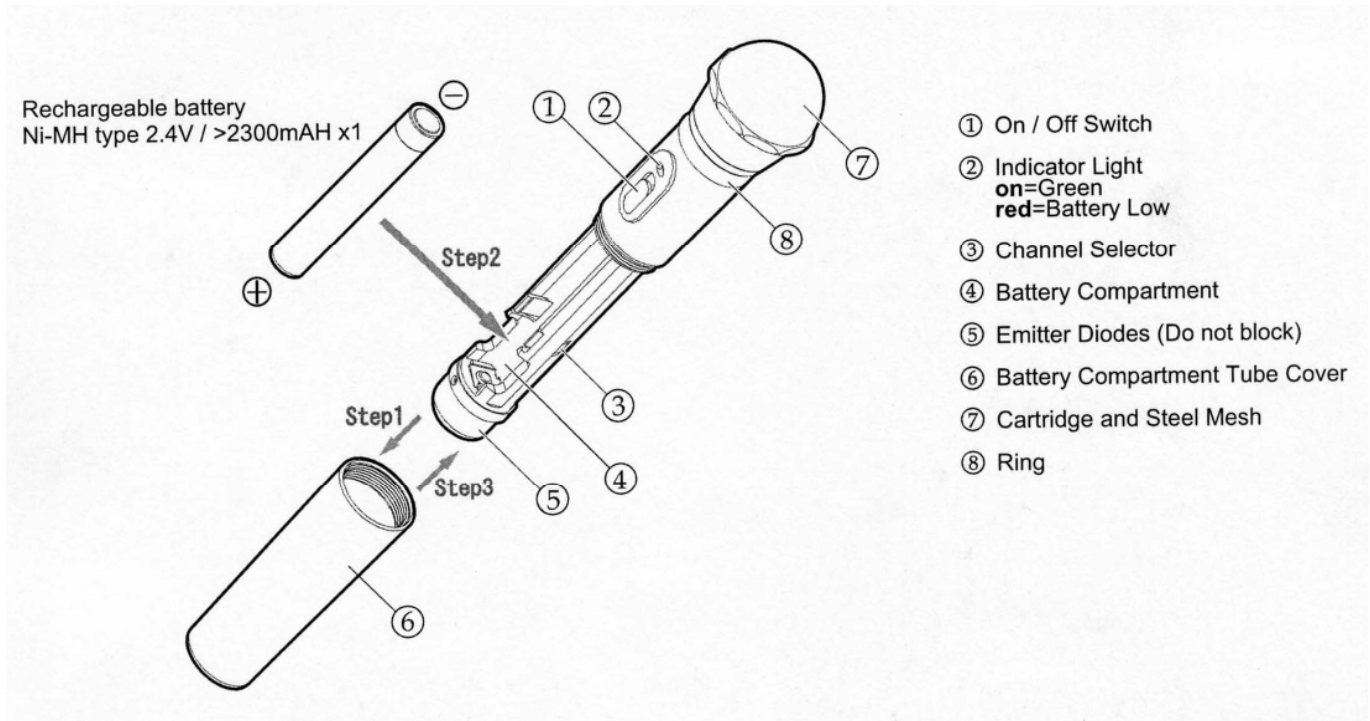

Speakers:

Ceiling Speakers (SP - 628) The ceiling speakers are housed in a sealed metal back can with a trim ring and white grille. The speakers have three quick mount clamps to mount the speaker in a ceiling tile with support of a tile bridge. Plenum rated wire is provided for connecting the speakers to the amplifier. A standard speaker package has four speakers but the quantity may vary per order.



Wall Mount Speakers (SP – 2000) Wall mount speakers are rectangular shaped enclosure with a woofer and a H.F. tweeter. Wall brackets are included for mounting the speakers. Plenum rated wire is provided for connecting the speakers to the amplifier. A standard speaker package has four speakers but the quantity may vary per order.

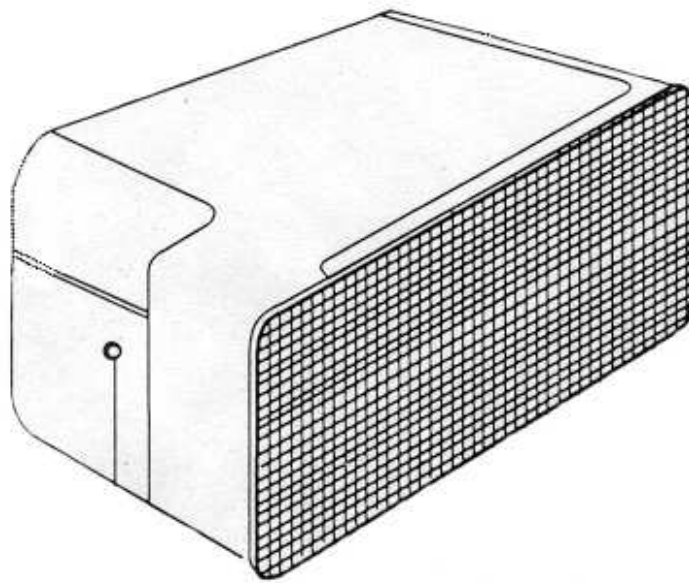

PRIOR TO INSTALLATION

Be sure to observe all safety precautions

- Wear goggles when using power tools.
- Observe all safety guidelines when using ladders
- Do not install your system near water or heat sources
- Wear proper work clothing, avoid loose tails and sturdy shoes
- Clean all components with a dry cloth
- Use Teachlogic accessories only
- Protect all cables from abrasion, sharp edges, and install in a tidy manner

The following Basic Tools and Supplies will be Required to Install the System

- Safety Goggles
- Power Drill Motor & Drills
- Phillip #2 Screw Driver
- Level & Tape Measure
- Side Cutter & Scissor
- Hammer
- Staple Gun & Staples
- Plastic Cable (zip) Ties
- Plastic or Metal Raceway & Screws (If external wiring is required)
- Aviation Metal Cutters
- Ladder
- Keyhole or Drywall Saw
- Electrical Tape
- Twine or Light Weight Pull Rope

INSTALLATION INSTRUCTION FOR THE SPECTRUM II SYSTEM

Organize and Plan Your Installation

Upon arrival at the jobsite, observe the following Criteria:

- Observe the type of ceiling to determine your method of installing the speakers
- Roughly layout the location of each speaker
- If wall mount speakers are being installed, determine the mounting location.
- Where and how will the Spectrum (Receiver / Amplifier) be installed
- What will be the best routing of the speaker wires
- Where are the Auxiliary Audio Sources located and how will they be Interfaced with the sound system
- Determine the central location of the ceiling for installation of the dome sensor and the routing of the sensor cable to the receiver / amplifier

Installation Procedure

Installation of the Spectrum II Receiver / Amplifier

Placement of the Spectrum amplifier is usually dictated by the other electronic equipment associated with the sound system in a rack and / or the location of the auxiliary audio/video equipment to be integrated with the amplifier. Also, the routing of the speaker and sensor cables will be factor to consider.

Installing the Spectrum II in a standard electronic equipment rack

- Use the RM – 700 rack mount kit.
- Mount the tabs on the side of the amplifier
- Install the amplifier in the rack at desired location

Installing the Spectrum II under or above a Shelf or Support

- Use the SM – 700 shelf mount kit
- Using either of the mounting holes, mount the four tabs on the sides of the amplifier with the 90° tab pointing either inward or outward.

- Hold the amplifier in position and mark the mounting holes
- Drill the holes for the mounting hardware being used for mounting
- With tabs oriented outward, install the Spectrum II on or under the shelf.
- With tabs oriented inward, remove the tabs and install them on the shelf.
- Mount the amplifier within the mounted tabs

Installation of Speakers

The Spectrum can accommodate up to eight (8Ω) speakers. Normally, four speakers will be adequate to distribute the sound evenly throughout a normal classroom of approximately 2500 sq. ft.

When installing ceiling speakers in a dropped ceiling, layout the speakers equidistant above the listening area.

Installing the SP – 628 Ceiling Speaker

- After cleaning hands, remove the tile bridge from ceiling grid
- Lay ceiling tile face down on clean flat surface
- Center the large hole of the tile bridge on the ceiling tile
- Trace and then cut the circle in the tile using a keyhole or drywall saw
- While the ceiling tile is removed, place the speaker cable in ceiling plenum and advance the roll to the next speaker location while holding the end to be connected to the speaker
- Remove the speaker grille using a pointed tool to lift out of trim ring
- Insert speaker into ceiling tile and place tile bridge over speaker
- With tile bridge in place, tighten the three quick clamps to snug
- Connect speaker wire to speaker; Wire inscribed “TeachLogic” is designated as the “Positive” lead. It is important to observe speaker polarity to maintain proper phasing between speakers and amplifier.
- Reinstall ceiling tile and speaker grille.
- Remove any soil and fingerprints
- Repeat the process for each speaker while routing the individual speaker cables toward location of the Spectrum amplifier

Installing the SP-2000 Wall Mount Speakers

- First observe: shape of the room, ceiling height, door locations, windows, mounting surfaces and seating area. In a rectangular or square room, you

would try to locate the front two speakers (one on each side) approximately even with the front row listeners. Locate the other pair approximately mid-way to the rear of the listening area.

- Mount the speakers at least 6 feet above the floor. Using the most appropriate fastener, mount the speaker brackets on the wall in vertical orientation.
- Mount the speakers in the brackets and direct them toward the center and pointed mid way toward the rear.
- Connect the speaker wires, observing the lead with Teachlogic imprinted is the positive polarity.
- Routed the speaker wires to the Spectrum amplifier, observing safe and protective enclosure.
- Remove any soil, fingerprints and debris.

Installation of the Dome Sensor

The ideal location for the dome sensor would be in the center of the ceiling. This will provide a clear signal path for the IR transmission from the transmitter to the dome sensor without obstruction. In addition, you will have 360° coverage and will minimize the transmission distance for more reliable performance.

- Locate the center ceiling tile and the approximate location for the sensor.
- Remove the tile and measure & mark the center location.
- Drill or cut a 3/4" hole through the tile.
- Place the mounting bracket across the center hole and drill two holes, one on each side nearest to the center hole for the mounting screws.
- Mount the sensor with the two screws provided.
- Connect the sensor cable to the dome sensor.
- Advance the roll of sensor cable toward its exit point going to the amplifier.
- Reinstall the ceiling tile.
- Remove any soil, fingerprints and debris.

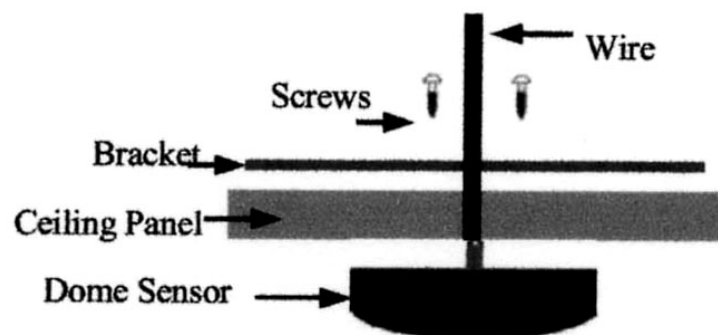

Installing the Dome Sensor on a Hard Surface

- Observe the notches and the grooved lines
- Hold bracket with the two center grooved lines facing up
- Bend the side straps at the grooved lines up toward you, little less than 90°
- Bend the end straps at grooved lines in the opposite direction
- You should now have bracket that is U shaped with side mounting tabs
- Mount the bracket to the sensor with the short screws provided
- Connect cable to the sensor
- Locate the center of the ceiling and mount sensor to the ceiling with appropriate fasteners
- Route the sensor cable either up through the ceiling if feasible or surface mount using a raceway or the use of self adhesive wire tie pads & wire ties
- Route to the Spectrum II amplifier
- If surface mounting, observe straight taut runs and in a tidy manner
- Remove any soil, fingerprints and debris
-

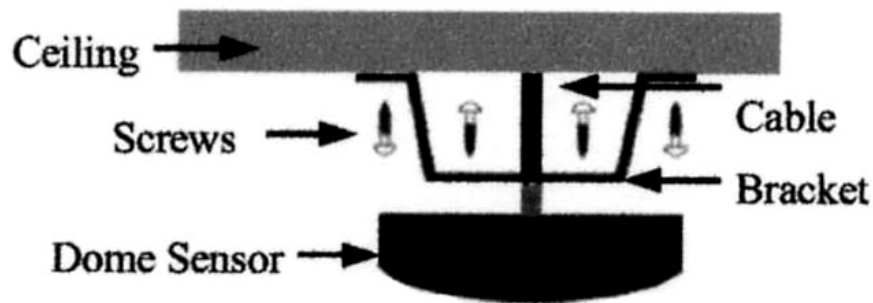

Final Connection of the System

With all the speaker wires and the sensor cable neatly routed to the amplifier, we are ready to complete the installation.

Connecting the Dome Sensor

- Coil up the excess cable (if there is excess) and place it out of the way and view
- Plug the sensor into any one of the sensor input jacks (RCA)

Connect the auxiliary audio sources

- The auxiliary input jacks are dual RCA. They are labeled on the back corresponding to the volume control on the front panel. Interconnect to each source using a shielded cable with the proper connectors.
- You can use stereo connectors into the Spectrum's dual inputs. The two channels will be summed internally so both channels will be passed through

Connecting the Speakers

- Cut the speaker wires to the proper length.
- Split the cable and strip approximately $\frac{3}{8}$ inch off each wire.

- Twist the stranded wire and if you have a soldering iron, it is a good practice to tin the wire ends.
- It is important to observe speaker polarity
- Unplug the phoenix connector and insert the positive wire (one with TeachLogic imprinted) into either outside screw terminal. Insert other wire into the next slot. Tighten the set screw. Do same for all the speaker connections.
 - If you are using more than four speakers, connect the additional speaker into the other two slots of the phoenix connector. Be sure to observe the polarity, insert the labeled lead configuration will parallel the two speakers connected.
 - Plug speaker phoenix block into the amplifier speaker output terminal.

Page Over-ride / Pass Through Feature

The page over-ride feature allows you to connect a speaker level signal to the page over-ride input and the system will mute all the inputs and pass the page through into the classroom.

- Unplug the two-terminal phoenix connector.
- Connect the speaker cable from the paging system to the phoenix connector.
- Determine the signal level of the paging system (8Ω, 25 v, 70 v, or 100 v).
- Set the slide switch to the appropriate speaker level setting.
- Plug the phoenix connector into the page over-ride jack
- With the Spectrum II turned “ON”, send a page signal through the page input.
- Adjust the page volume in the room to the desired listening level using the gain control on back panel.

Nine Band Equalizer

If you have a pink noise generator and an octave analyzer, you can adjust the sound spectrum to your desired listening criterion. Without instruments you will have to rely on your listening ability and experience. Adjust the equalizer to compensate for the room acoustics to achieve maximum clarity and intelligibility.

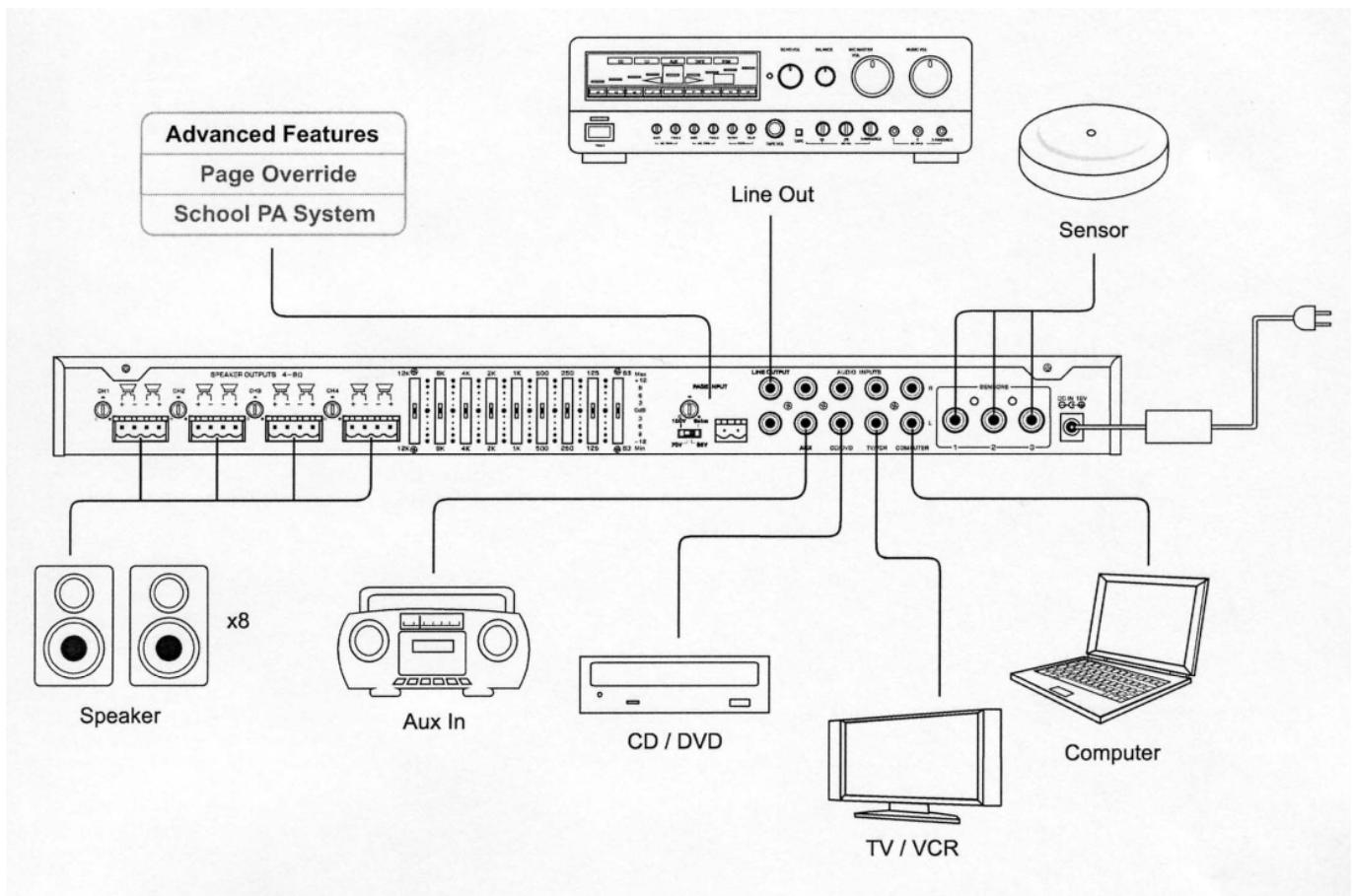

Operating the System

Now that the system has been installed and adjusted per the instructions above, we are now ready to test the input side of the system. The inputs will include the wireless infrared microphones and auxiliary audio sources.

Body – Pack Transmitter and its Features

- A microphone needs to be plugged into the Body-Pack
 - The Plug-in microphone is a small capsule that plugs directly into the top of the body-pack transmitter. Then install the lanyard (included) under the spring clip and slip it over your head to be worn as a pendent type microphone.
 - The Lapel microphone plugs into the mic input and then the lapel mic is clipped on to your clothing.
 - The Collar microphone plugs into the mic input and the collar is formed around the neck with the microphone element oriented toward your mouth.
 - The Ultra Lite Mic is fitted around the ear and the cable plugged into the mic input.
- The body-pack is powered by two rechargeable NiMH batteries which need to be fully charged for optimum performance
- Turn “on” the body-pack via slide switch on side of the body-pack
- Observe the Green LED on top of transmitter (Good charge on battery)
- Also observe the LED next to Ch. A volume control indicating IR signal being received when the body-pack is turned “on”

- If the Ch. B LED turns “on”, remove the battery cover and slide the channel selector switch to Ch. A.
- Speak into the microphone and adjust the volume using the gain control on top of the body-pack and Ch. A volume control on the Spectrum II.
- While talking, walk around the perimeter of the room to verify 100% reception of the signal.
- Upon completion of test, put the belt-pack in the charger for recharging

Handheld Microphone Transmitter and its Features

- The handheld microphone is powered by two rechargeable NiMH batteries which need to be fully charged for optimum performance
- Turn “on” the microphone with slide switch and observe the Green LED
- Also, observe the LED next to Ch. B volume control indicating IR signal being received when the body-pack is turned “on”
- If the Ch. A LED turns “on”, unscrew the bottom half of the handheld and slide the channel selector switch to Ch. B.
- Speak into the microphone and adjust the volume using Ch. B volume control on the Spectrum II.
- While talking, walk around the perimeter of the room to verify 100% reception of the signal.
- Upon completion of test, put the microphone in the charger for recharging

Drop-in Battery Charger

The battery charger is a rather sophisticated charger. It will charge the NiMH batteries at the optimum charge rate, maintain full charge, and will recycle the batteries for extended battery service life.

- Plug the charger into an AC outlet
- Place handheld microphone and / or body-pack transmitter into their appropriate slot
- When a microphone is being charged, a Red LED will light indicating unit is being charged
- When the batteries are fully charged, the LED will change to Green.
- There is an audible buzzer which will buzz an alert when the batteries are fully charged. The buzzer can be turned “on or off” with the slide switch located on the bottom of the charger. (The charger is normally shipped with the switch in the “off” position).

Congratulations, this completes the installation and it is now time to show the user how to use the system

User Instruction

- Turn “on” the Spectrum via the power switch at the lower / left corner, red LED will light
- Plug a microphone into the body-pack and set the gain control at zero (max. CCW)
- Turn the body-pack transmitter “on” via slide switch on the side of transmitter
- Observe the Green LED on the body-pack indicating a useable charge on the batteries
- Observe the Red LED near the Ch. A volume control, it indicates a signal being received from the body-pack
- Turn Ch. A volume to approximately mid scale (12 o'clock)
- While talking into the microphone, slowly turn the gain control CW until you've achieved a comfortable listening level
- Using the Handheld microphone, turn it “on” the Green LED will light and the Red LED adjacent to the Ch. B control will light indicating signal presence from the handheld microphone
- Slowly turn the Ch. B volume control CW until the desired listening is achieved
- Now venture around the room while alternately talking into each microphone. Observe no interruption or drop outs while moving about
- Connect the auxiliary audio sources (computer, projector, DVD player, VCR) using a shielded cable with appropriate connectors, plugging into the designated RCA jacks

- Turn each audio source “on” and engage their operation. Adjust the volume level of each auxiliary input to the desired listening level. If the output is distorted or overly sensitive, it is probably due to the signal output of the audio device being too strong and is over driving the auxiliary input of the Spectrum II.
- Once all the auxiliary inputs have been verified and adjusted, the system is ready for full operation

Trouble Shooting

- System is turned “on” but there is no sound
 - Verify the AC power; the red LED is not lit.
 - Check if system has been unplugged
 - Check circuit breaker
 - Call maintenance for assistance
 - System has power but still no sound
 - Turn “on” microphone and check for signal presence (Green LED next to volume control)
 - No signal presence, LED not lit
 - Check Green LED in center of dome sensor
 - If sensor LED is not lit, the dome sensor has either been disconnected or the power for the sensor has failed
 - If LED is lit but there is no sound
 - If either condition is not resolved, send unit in for repair
- When using the microphone, the voice is distorted and / or signal drop out occurs
 - Check the charge on your batteries
 - Recycle the batteries by placing the transmitter in the charger and press the grey button and hold for 3-5 seconds
 - The yellow LED will light and the charger will automatically discharge the batteries and then recharge to full charge. (Time required 4 -6 hours)
 - Recheck the system after cycling the batteries

- If the problem persists, replace the batteries
- When using the body-pack transmitter and microphone, the voice is intermittent and / or has a static like sound
 - Try moving the cable back and forth at the plug-in connector or where it is connected to the microphone
 - If the noise and intermittent connection is associated with the movement of the cable, the cable connection needs to be repaired

If your problem persists and this guide has not resolved the issue, call our customer service department for additional assistance. (800) 588-0018

GENERAL SPECIFICATIONS:

IMA – 700 SPECTRUM II RECEIVER / AMPLIFIER

Receiver Input	Infrared FM Modulated
No. of Channels	Two
Frequency	Channel A : 2.08 MHz Channel B : 2.54 MHz
Infrared Wavelength	850 nm
Modulation	FM wide-band
De-emphasis	50µS
Frequency Response	50Hz – 15KHz
S/N Ratio	>65dB
THD	<1% @ 1KHZ
Nominal Deviation	±10KH
Maximum Deviation	±25KHz
Aux. Output	Line Level
Input Level	1V / 1KΩ
Four Aux. Inputs	Line Level, RCA
Power Output	Four Amplifiers, 18 watts ea.
Output Impedance	4Ω
Page Over-Ride	Input: 8Ω, 25v, 70v, 100v
Equalization	Nine Band
IR Sensor Input	Three Phantom Powered, RCA
ALS Output	3.5mm with Gain Control
Power Supply	19VDC / 4.75A
Size	17" W x 1¾"H x 7½"D

Weight 6.5 lbs. (including Pwr. Supply)

IRB - 30 BODY-PACK TRANSMITTER

Transmission Carrier	Infrared Ray
Carrier Frequency	Channel A: 2.08 MHz
(field switchable)	Channel B: 2.54 MHz
Modulation	FM wide-band
Pilotone Frequency	32.768KHZ
IR Wavelength	850 nm
Peak Deviation	±25KHz
No. of Emitting Diodes	Ten
Compander Circuit	Yes
Pre-emphasis	50µS
IR Emitter Location	Built-in
Transmission Angle	360°
IR Power Output	High - Low Selectable
Current Consumption	Hi - 400ma Lo - 330 ma
Range	Hi about 30 yds. Lo about 20 yds
Microphone Input	3.5mm jack, Lo-z
Battery	Two Rechargeable NiMH, 1.2v / 2300mAH
Battery Life	Approximately 7 Hours
Dimensions	4 ³ / ₈ " H x 2 ⁵ / ₈ " W x ³ / ₄ " D
Weight	4.8 oz. (with batteries)

IRH - 30 HANDHELD TRANSMITTER

Transmission Carrier	Infrared Ray
Carrier Frequency	Channel A: 2.08 MHz
(switchable)	Channel B: 2.54 MHz
Modulation	FM wide-band
Pilotone Frequency	32.768KHZ
IR Wavelength	850 nm
Peak Deviation	±25KHz
No. of Emitting Diodes	Ten
Compander Circuit	Yes
Pre-emphasis	50µS
IR Emitter Location	Built-in
Transmission Angle	360°
Current Consumption	330ma
Microphone Element	Unidirectional, Dynamic
Battery	Two Rechargeable NiMH, 1.2v / 2300mAH
Battery Life	Approximately 6 Hours
Housing	Aluminum
Dimensions	10" L x 1 ¹ / ₂ " Dia.
Weight	11.4 oz. (with batteries)

BRC - 30 DROP- IN BATTERY CHARGER

Charging Slots	Two Handheld, Slots A & C
	Two Body-Pack, Slots B & D
Charging Mode	Switching
Charging Current	1700ma ±10%

Discharge Rate	350ma
Red LED Indicator	Batteries being Charged
Green LED Indicator	Batteries Fully Charged
Yellow LED Indicator	Batteries being Discharged
Audible Alert	Intermittent Buzz - Batteries Fully Charged
Recycle Button (Grey)	Press for Full Discharge and Auto Recharge
Auto Switching	Switch from Discharge to Charge Mode
Charging Time	1.5Hr. / Slot
Power Supply	12VDC / 1.5A (Fuse protected)
Dimensions	6½" L x 3¾" W x 1½" H
Weight	12.2 oz.

ICS - 50 CEILING DOME SENSOR

Operating Frequency	2MHz to 2.6 MHZ
Number of IR LED's	30 Radial Spaced
Interconnection	50Ft. Plenum Rated Shielded Cable, RCA Connectors
Operating Range	50 – 60 Feet Line of Sight
Reception Area	2500 Ft. ²
Power Indicator	Green LED
Reception Angle	360° Semi-Spherical Coverage
Dimensions	5" D x 1½" H
Weight (with 50' cable)	1.2 lbs.